

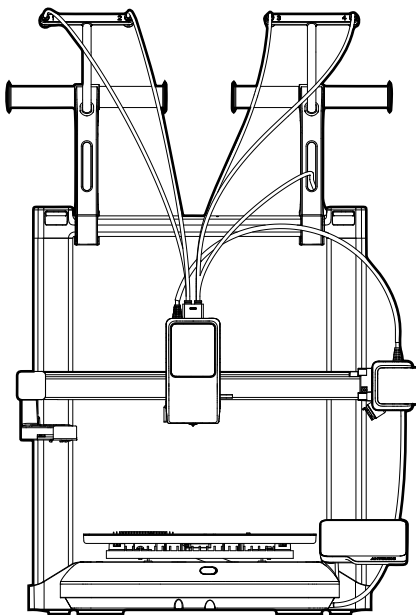

Anycubic Kobra X User Manual



Support Center
(with installation video
and slicer installation guide)

The pictures are for reference only,
please refer to the actual product.

Thank you for purchasing **ANYCUBIC** products!

Even if you are a long-time **ANYCUBIC** user or an expert in 3D printing, we highly recommend reviewing the precautions and setup tips in this manual. Every printer is unique, and following these steps ensures optimal performance and safety. For advanced troubleshooting or topics not covered here, please visit our official support portal at anycubic.com.

To enhance your printing experience and master your machine, explore our additional resources:
Anycubic Wiki: Scan the QR code to access our comprehensive knowledge base, including setup guides, deep-dive tutorials, and troubleshooting tips.



ANYCUBIC
Slicer



ANYCUBIC Wiki



ANYCUBIC
Official Website



ANYCUBIC
App

*The copyright of this manual belongs to Shenzhen ANYCUBIC Technology Co., Ltd. Any reproduction without permission is prohibited.

ANYCUBIC Team

Table Of Contents

1 Product Introduction 1

2 Product Installation 3

Install the Printing Plate 3

Unlock the Printer Frame Z axis 4

Install the Printer Frame 5

Connect the Printhead, Camera
and XZ Axis Motor Cables 6

Install the Purge Wiper 7

Install the Spool Holder 8

Install Teflon Tube 9

3 Power on 10

4 Filament Feeding 11

5 Bind Printer 12

APP 12

Slicer 13

6 Upgrading the Firmware 15

7 Machine maintenance 16

8 Precautions 17

Products at a Glance

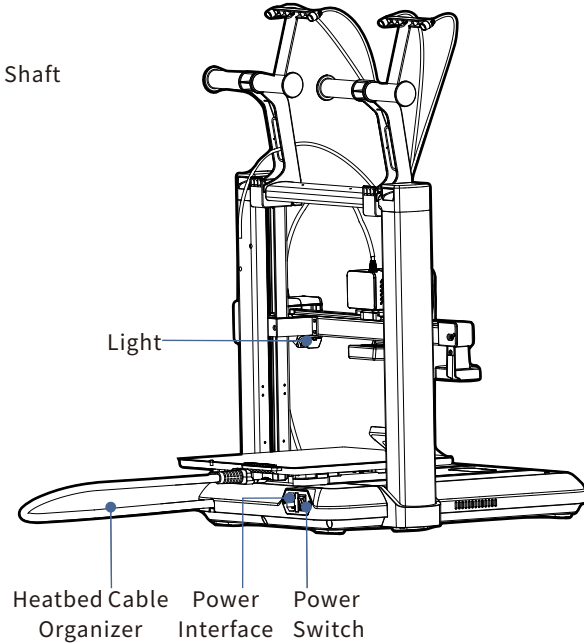
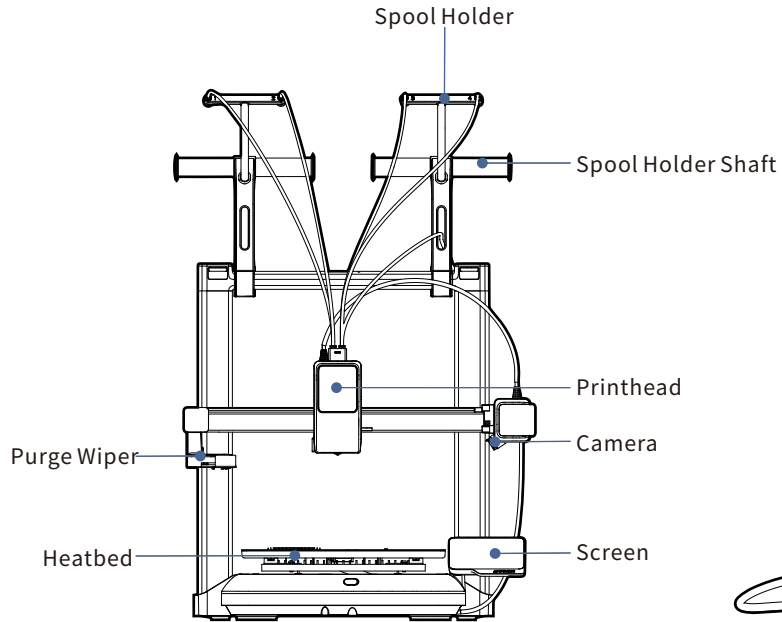

Packing List

Note: The following pictures are for reference only.
Please refer to the actual product received.

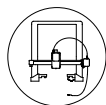

Gantry Frame

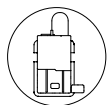

Printer Base



Power Cord

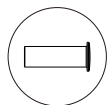

Spool Holder
Shaft(4pcs)

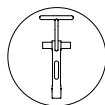

Spool Holder
(2pcs)

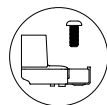

Purge Wiper
&M3*8(1pcs)



M5*30(8pcs)



Cable Clip
(1pcs)

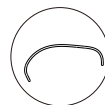

Teflon Tube
(4pcs)



Filament Samples

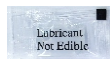

Grease



Nozzle Cleaner



4.0/2.5/2.0
&Magnet



Decorative Cover
(2pcs)

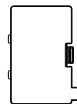

Cable Cover



Printing Board



Application
Brush

Specifications

Printer Parameters

Printing Principle:FDM (Fused Deposition Modeling)
Print Volume:260 mm (L) × 260 mm (W) × 260 mm (H)
Print Layer Thickness:0.08 - 0.28 mm
Heatbed Temperature:100°C
Number of Nozzles:Single nozzle
Nozzle Diameter:0.4 mm
Consumables:PLA/TPU/PETG/ABS etc.

Software Parameters

Slicer:AC Slicer/PrusaSlicer/Cura
Input Format:STL , .OBJ
Output Format:GCode
Connection Method:Anycubic APP,Anycubic Slicer

Power Supply Parameters

Power Input:110 V~ ,60 Hz
Rated Power:1450 W

Wi-Fi

Frequency Band:2.4 GHz,5 GHz
Working Mode:STA, AP+STA Blending Mode

Physical Parameters

Machine Size:455.4 mm (L) × 445.3 mm (W) × 461.3 mm (H)
Maximum Size of the Machine
(including spool holder and heatbed moving forward and backward):
455.4 mm (L) × 635.0 mm (W) × 685.1 mm (H)
Machine Net Weight:9.5 kg

Product Installation

1 Install the Printing Plate

1. Carefully remove the print plate and printer base.
2. Place the build plate onto the hotbed with the silkscreened side facing up. Ensure the edges of the plate are perfectly aligned with the edges of the hotbed for a secure fit.

Scan the QR code on the right to watch a step-by-step installation video.

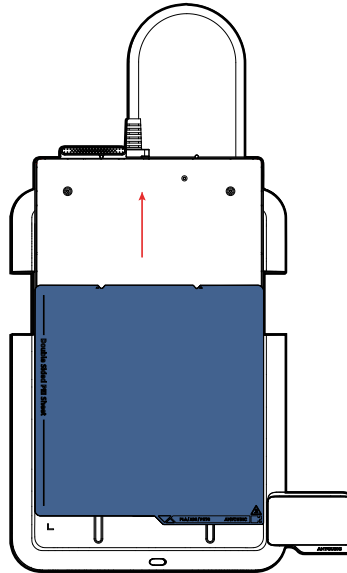

② Unlock the Printer Frame Z axis

Use the H2.0 hex wrench to loosen the six screws securing the Z-axis gantry fixtures. There are three screws on each side; follow the same procedure for both the left and right fixtures.

*Pro Tip: To prevent screws from falling during assembly, slide a magnet along your hex wrench to magnetize it. Positioning the magnet closer to the tip will increase the magnetic pull, making it easier to hold screws in place.

Attention: Unlock before powering to prevent permanent hardware damage, you must unlock the Z-axis before turning on the power. Do not connect the power cable until the Z-axis is fully released. ⚠

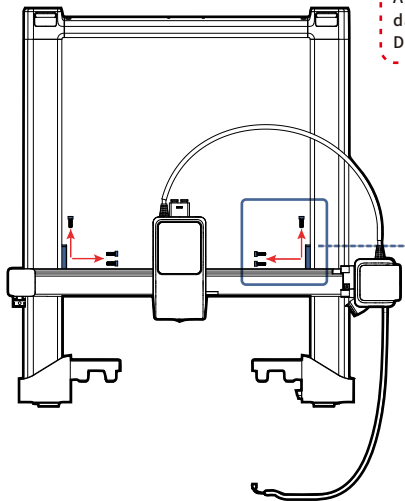

Unlock the Z axis

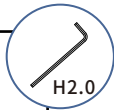
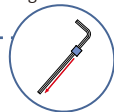
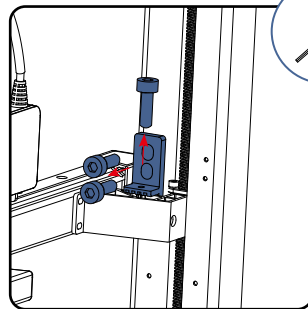

3 Install the Printer Frame

1. Hold the top horizontal axis and manually lift the X-axis to approximately 3/4 of the way up the Z-axis. This provides clearance for the base installation.
2. Slide the hotbed and printer base toward the front of the machine to reveal the locking positions for the gantry.
3. Use an H4.0 hex wrench, install the eight M5*30 screws (four per side) to secure the gantry to the base. Tighten the screws from top to bottom.
4. Reinstall the decorative covers by pressing them down until they snap into place.

① Raise the Z Axis

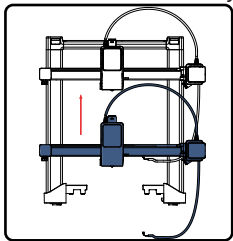

② Reveal Locked Position

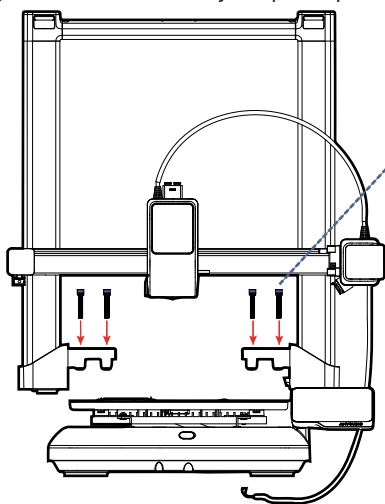
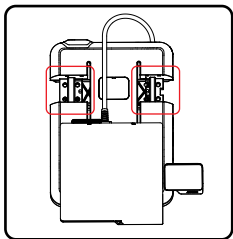

③ Lock Screw

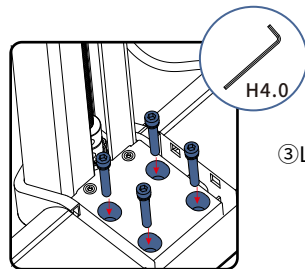

④ Put on the Decorative Cover

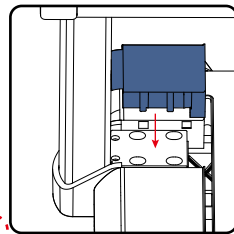

Note: For the final tightening, it is recommended to hold the long end of the hex wrench. This provides greater leverage to ensure all screws are securely fastened.



④ Connect the Printhead, Camera and XZ Axis Motor Cables

1. Tilt the printer backward to expose the underside of the base.
2. Connect the single-pin connector between the base Z-axis port and the bottom-right port of the gantry. For the 3-pin connector, connect the X-axis, printhead, and camera (CAM) ports in descending order of pin count, then tuck the wires into their designated slots.
3. Reinstall the cable cover to protect the connections.

Note: Please ensure each connector is connected to its matching port by verifying the number of pins on each plug. Match the connector size to the corresponding socket to ensure a correct and secure connection. ⚠

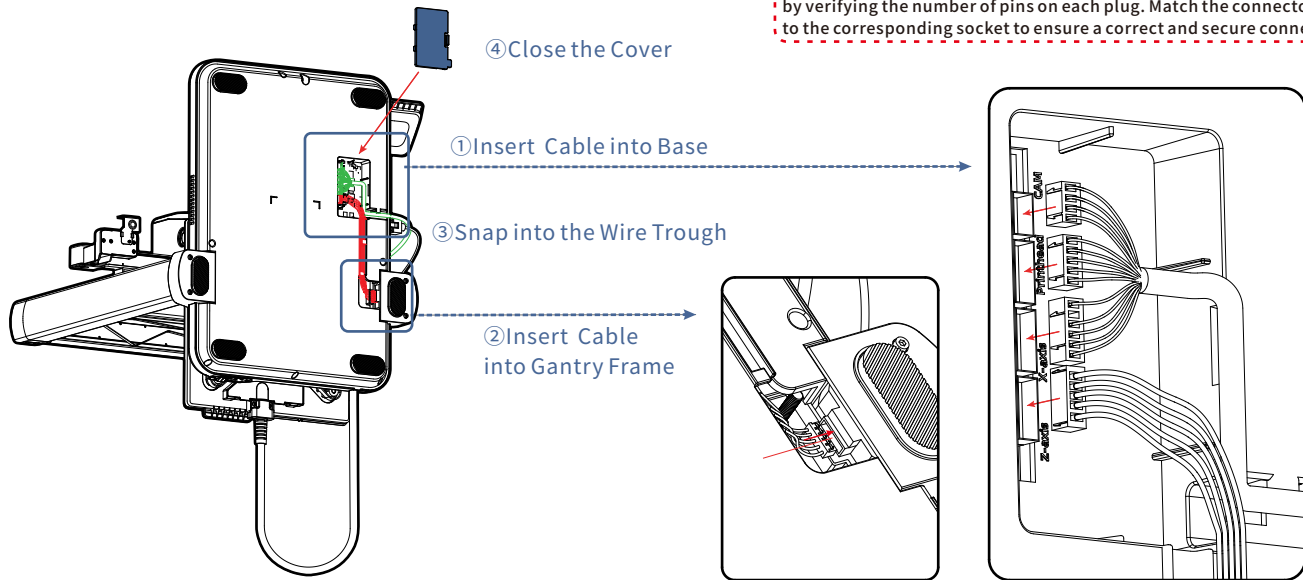

5 Install the Purge Wiper

1. From the front of the machine, slide the purge wiper toward the back until it is firmly seated in the left side of the gantry.
2. Use an H2.0 hex wrench to tighten the M3*8 self-tapping screw from the rear of the unit, securing the purge wiper to the frame.

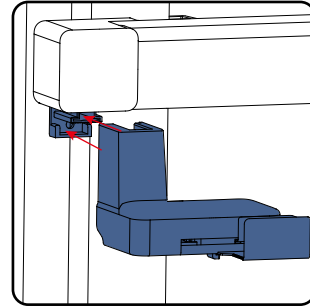
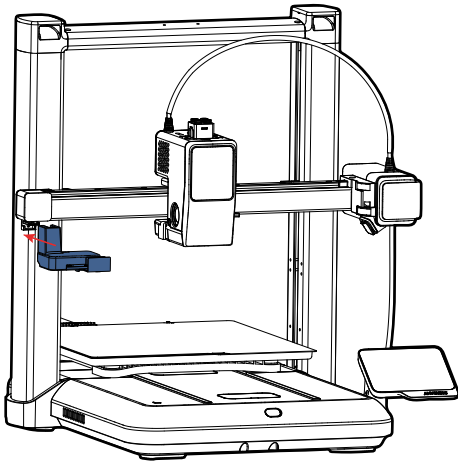

① Insert into the Slide

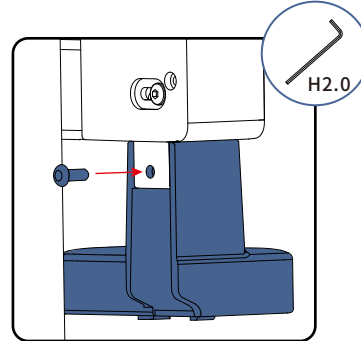

② Lock Screw

6 Install the Spool Holder

1. Insert the support rods into both sides of the spool holder. Push and rotate the rods until they are fully seated, then rotate them downward to lock them firmly into place.
2. Once the spool holders are assembled, snap them onto the left and right sides of the printer frame's top horizontal axis.

Note: For easier filament changes, you can slide the spool holders along the top horizontal axis to your preferred position on the left or right. 

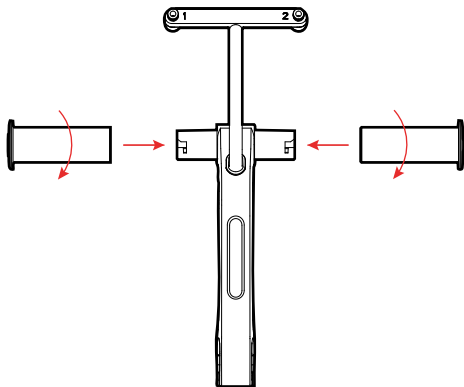

① Assemble the Spool Holder

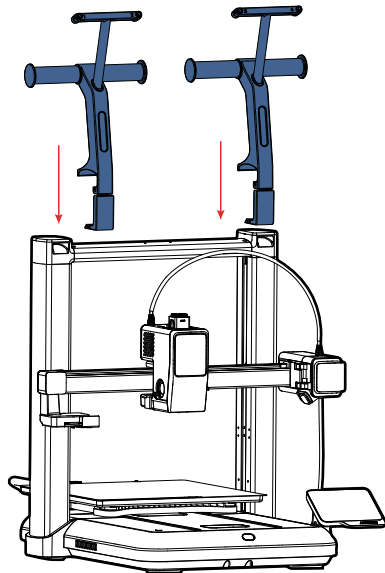

② Install the Spool Holder

7 Install Teflon Tube

Insert one end of each of the four teflon tubes into the holes above the printhead, and the other ends into the feed ports on the front of the spool holders. (*After completing all the above operations, you can power the machine using the power cord.)

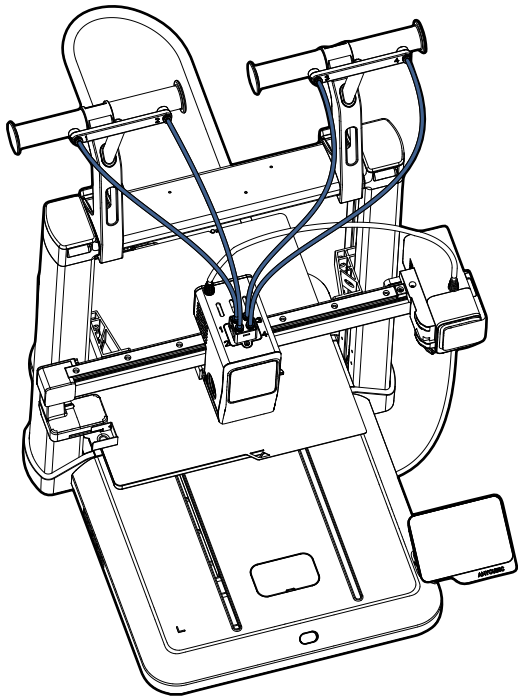

Note: Match each tube to its designated port according to the number markings. 

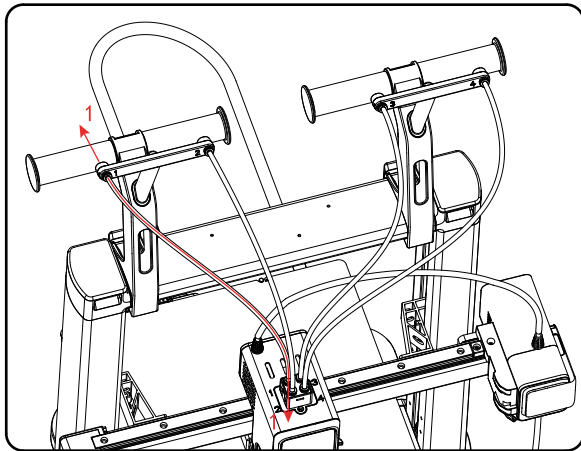

Power on

① Boot Page



② Language Selection

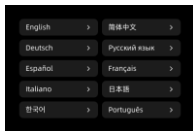

③ Region Selection

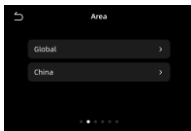

④ Network Connection

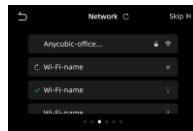

⑤ APP Download



⑥ Security Confirmation



⑦ Self-check Reset to Zero



⑧ Resonance Compensation



⑨ Auto Leveling

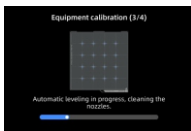

⑩ Active Noise Cancellation

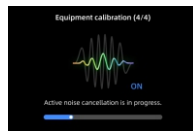

⑪ Calibration Complete



Makeronline QR code:
(Download the latest model
via Makeronline)



Note: The UI shown is for reference only. Due to continuous feature enhancements, please refer to the latest firmware for the most up-to-date interface.



Filament Feeding

1. Place the filament spool onto the holder. For the smoothest extrusion, ensure the spool rotates in the same direction as the filament feed (see diagram below).
2. Insert the filament into the extruder. A beep and a display update showing the material type and color will confirm a successful load.

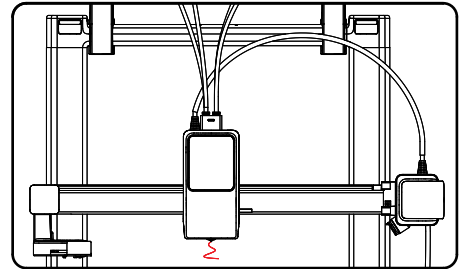
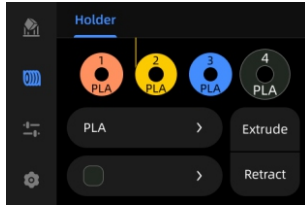
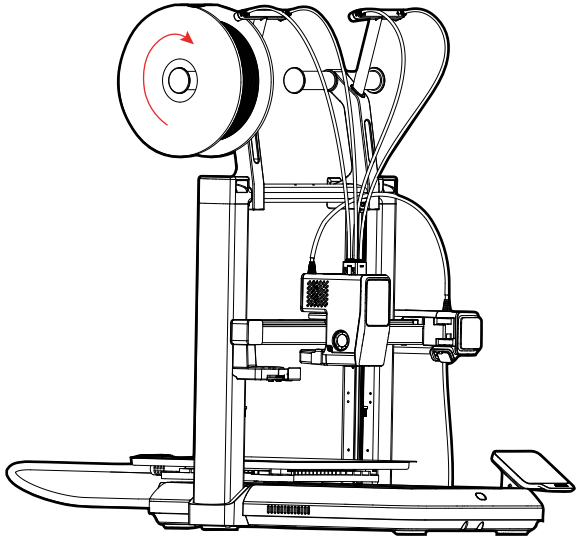

Add a Printer on the APP

1. Connect your printer to the internet.
2. Scan the QR code on the printer screen. Go to [Settings] - [Account]. Download the ANYCUBIC app, register, and log in to your ANYCUBIC account.
3. Open the ANYCUBIC app, tap "+Add Printer," and scan the QR code on the printer screen to link your ANYCUBIC account.

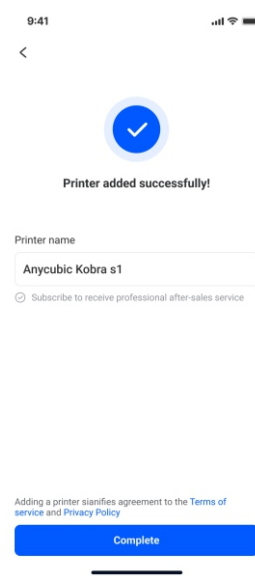
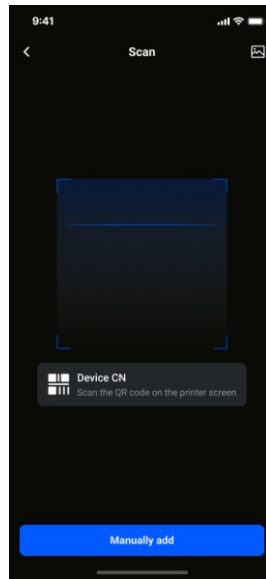
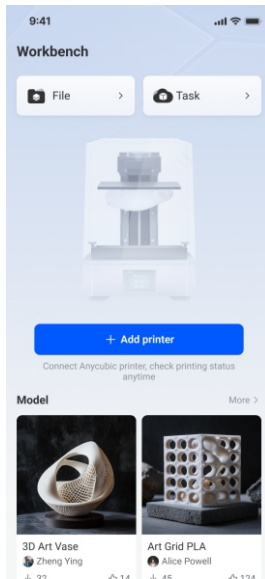
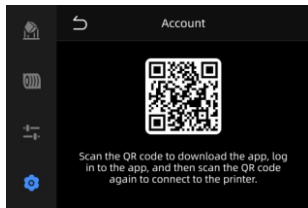

Slicer Installation and Printer Addition

Slicer download:



1. Download and install the Anycubic Slicer by scanning the QR code on the right or visiting: anycubic.com/slicerNextDownload.
2. Ensure your printer is powered on and connected to the internet before proceeding with remote setup.
3. Launch the software and navigate to the Workbench or Login section to link your printer and begin remote printing.

① After the software is installed, go to the main page and click [Login/Register]. ② If you already have an Anycubic account (the same one used for your mobile app), enter your

credentials to log in. New users can select [Sign Up Now] to create an account.

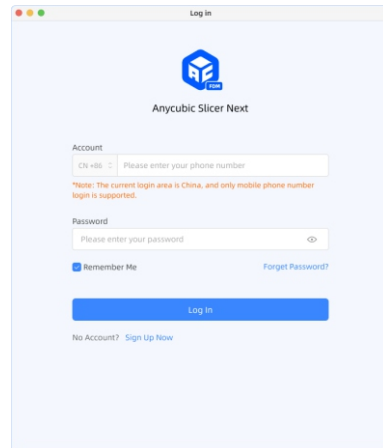
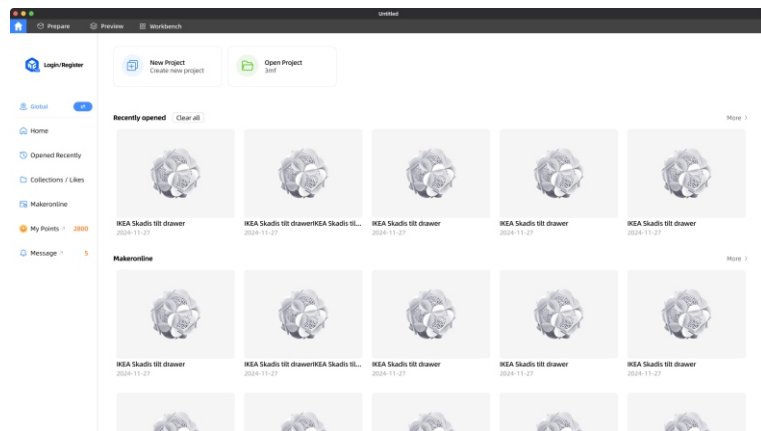

Note: The software interface is based on the latest version.



Slicer Installation and Printer Addition

③ Click [Workbench] and select [Add Printer].

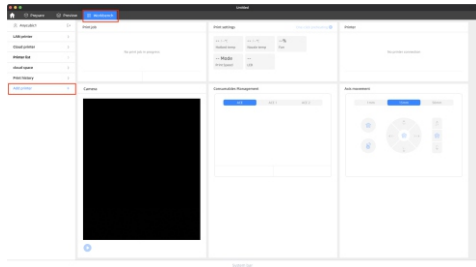

④ The software will automatically scan for printers on your local network and sync any devices already linked to your app. If your printer does not appear, select [Connect via CN Code] to link it manually.

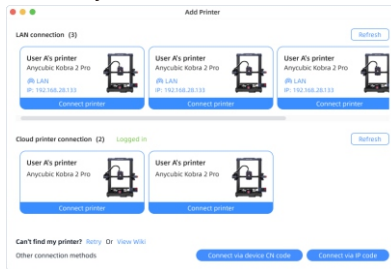

⑤ Locate CN Code: On the printer, navigate to [Settings] > [Device Info] > [Device CN Code] to view your unique connection code.

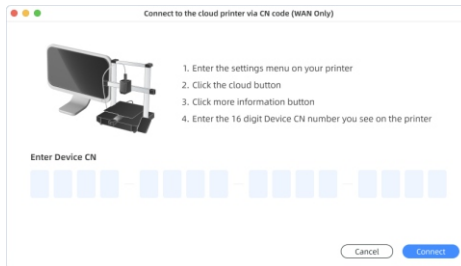

Upgrading the Firmware

Click on [Settings] - [Device Information] - [Firmware Version], and wait for the device to complete the firmware upgrade.

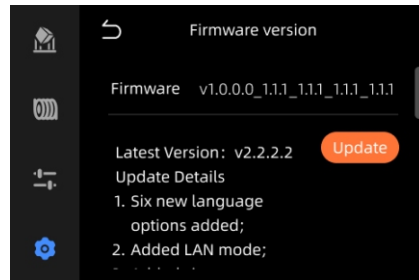
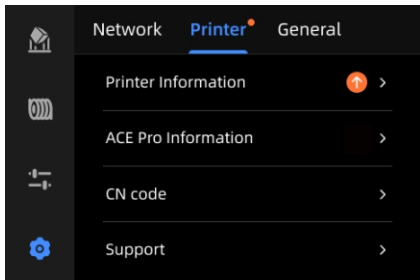

Machine Maintenance

3D printers are composed of complex mechanical structures and numerous moving parts. In order to ensure their stable operation and obtain high-quality printing results, regular maintenance and care are required.

Moving Metal Parts:

- Regularly lubricate the lead screw, linear rod, guide rail, idler pulley, and extruder wheel assembly to prevent rust.
- Lubricating oil can be used for the guide rail, linear rod, and idler pulley, while grease should be used for the lead screw and extruder wheel assembly.

Consumables:

- Regularly inspect plastic or rubber parts and cutter blades for signs of aging (including deformation) and damage.
- Replace parts such as silicone wipes and Teflon tubes as necessary.

Other Parts:

- Inspect the camera lens, fan, and filament sensor Hall effect components for debris or dust accumulation.
- Clean the fan with compressed air; gently wipe the camera with a lint-free cloth and isopropyl alcohol to ensure optimal cleanliness.

***We recommend using official Anycubic filaments. Anycubic has conducted extensive testing on these products to guarantee the best printing results.**



Scan the QR code to learn more about machine maintenance information

Precautions

- 1) The Anycubic 3D printer contains high-speed moving components. Keep hands and loose clothing clear of the motion system during operation to avoid injury.
- 2) If the printer will be idle for an extended period, store it in a cool, dry location protected from rain and moisture.
- 3) The printer generates extreme heat during operation. Never touch the printhead, hotbed, or freshly extruded material with bare hands.
- 4) The nozzle remains hot even after printing. Always wear heat-resistant gloves when performing maintenance or manual adjustments to prevent burns.
- 5) In the event of an emergency or malfunction, immediately switch off the power or disconnect the power cord.
- 6) Keep the Anycubic 3D printer and all small accessories (such as screws and cutters) out of the reach of children.
- 7) When replacing the fuse, use only a 250V / 10A rated fuse to prevent electrical damage or short circuits.
- 8) This device is equipped with a removable power plug. For safety, unplug the cord if the printer will be unused for a long duration.
- 9) Minor surface scratches on the build platform or slight texture variations in extruded material are normal and do not impact printing performance.

*Still have questions? If your issue remains unresolved, please contact our technical support team. Our engineers will review your request and provide a solution within one business day. (<https://support.anycubic.com/>)



After-sales support

Warm tips:

1. Fill in the information based on the SN of the corresponding model. Items marked with a red dot are required.
2. If the ticket is successful, you will soon receive a reply from the after-sales service system in your mailbox.
3. If you successfully place an ticket but do not receive an email, please check your spam/junk folder.
4. If the ticket creation fails, please pay attention to the pop-up reminder on the web page.

FCC Regulatory Compliance

WARNING: This device complies with part 15 of the FCC Rules.

Operation is subject to the following two conditions:

(1) This device may not cause harmful interference, and (2) this device must accept any interference received, including interference that may cause undesired operation.

Caution: The user that changes or modifications not expressly approved by the party responsible for compliance could void the user's authority to operate the equipment.

Note: This equipment has been tested and found to comply with the limits for a Class B digital device, pursuant to part 15 of the FCC Rules. These limits are designed to provide reasonable protection against harmful interference in a residential installation. This equipment generates, uses and can radiate radio frequency energy and, if not installed and used in accordance with the instructions, may cause harmful interference to radio communications. However, there is no guarantee that interference will not occur in a particular installation. If this equipment does cause harmful interference to radio or television reception, which can be determined by turning the equipment off and on, the user is encouraged to try to correct the interference by one or more of the following measures:

- Reorient or relocate the receiving antenna.
- Increase the separation between the equipment and receiver.
- Connect the equipment into an outlet on a circuit different from that to which the receiver is connected.
- Consult the dealer or an experienced radio/TV technician for help.

To maintain compliance with FCC's RF Exposure guidelines. This equipment should be installed and operated with minimum distance between 20cm the radiator your body: Use only the supplied antenna.



Disposal of Electronic Components

This symbol indicates that the device must not be disposed of with household waste. When this product reaches the end of its life, please dispose of it in accordance with local environmental regulations. Take it to a collection point for the recycling of waste electrical and electronic equipment. Proper disposal helps prevent environmental and health hazards caused by inappropriate handling of electronic waste. Recycling also supports the conservation of natural resources. Do not dispose of this product with unsorted municipal waste.



Entsorgung elektronischer Bauteile

Dieses Symbol weist darauf hin, dass das Gerät nicht mit dem Haushaltsmüll entsorgt werden darf. Am Ende seiner Lebensdauer entsorgen Sie dieses Produkt bitte gemäß den örtlichen Umweltvorschriften. Bringen Sie es zu einem Sammelpunkt für das Recycling von Elektro- und Elektronik-Altgeräten. Eine ordnungsgemäße Entsorgung hilft, Umwelt- und Gesundheitsgefahren durch unsachgemäße Behandlung von Elektroschrott zu vermeiden. Recycling unterstützt auch den Erhalt natürlicher Ressourcen. Entsorgen Sie dieses Produkt nicht mit dem unsortierten Siedlungsabfall.



Élimination des composants électroniques

Ce symbole indique que l'appareil ne doit pas être jeté avec les déchets ménagers. Lorsque ce produit atteint la fin de sa vie, veuillez l'éliminer conformément aux réglementations environnementales locales. Apportez-le à un point de collecte pour le recyclage des déchets d'équipements électriques et électroniques. Une élimination correcte aide à prévenir les risques environnementaux et sanitaires causés par une manipulation inappropriée des déchets électroniques. Le recyclage soutient également la conservation des ressources naturelles. Ne jetez pas ce produit avec les déchets municipaux non triés.



Eliminación de componentes electrónicos

Este símbolo indica que el dispositivo no debe desecharse con los residuos domésticos. Al final de su vida útil, por favor, dispóngalo de acuerdo con las regulaciones ambientales locales. Llévelo a un punto de recogida para el reciclaje de residuos de aparatos eléctricos y electrónicos. Una eliminación adecuada ayuda a prevenir los peligros ambientales y para la salud causados por una manipulación inapropiada de los residuos electrónicos. El reciclaje también apoya la conservación de los recursos naturales. No deseche este producto con los residuos municipales sin clasificar.



Smaltimento dei componenti elettronici

Questo simbolo indica che il dispositivo non deve essere smaltito con i rifiuti domestici. Al termine del suo ciclo di vita, si prega di smaltirlo in conformità con le normative ambientali locali. Portalo a un punto di raccolta per il riciclaggio di apparecchiature elettriche ed elettroniche usate. Uno smaltimento corretto aiuta a prevenire i rischi ambientali e per la salute causati da una gestione inadeguata dei rifiuti elettronici. Il riciclaggio supporta anche la conservazione delle risorse naturali. Non smaltire questo prodotto con i rifiuti urbani non differenziati.



Name: Lienco SAS
 Add: 8 Rue Marcel Cerdan, 77600, Bussy Saint Georges, France
 Contact: Ruoyu Zhang
 Tel: 0033766929910
 E-Mail: contact@lienco.eu



Name: WSJ PRODUCT LTD
 Add: Unit 1, Alsop Arcade, Brownlow Hill, Liverpool L3 5TX
 Contact: Michael
 Tel: +44 1519470193
 E-Mail: info@wsj-product.com

ANYCUBIC
合格证

品名: FDM/LCD
 检验员: 
 出厂日期: _____
 执行标准: GB4943.1

深圳市纵维立方科技有限公司
 地址: 广东省深圳市龙岗区园山街道银荷社区
 银海工业城11号厂房



M02010203